



MURPHY & READ SPRING MANUFACTURING CO.

www.MRspring.com

Extension Spring Reference Guide

Helical [extension springs](#) exert a force by pulling or stretching them. Usually, they are made from round wire and are close-wound with initial tension between the coils. Their ends can be formed with loops in many varieties to attach to their applications.

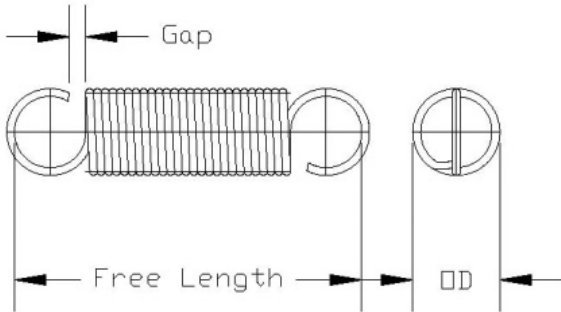

Spring Terms

OD = Outside Diameter

D = Mean Diameter

d = wire diameter

N_a = number of active coils

R = Spring Rate

P = applied force

S_t = torsional stress

S_b = bending stress (in loops)

IT = initial tension

c = spring index

ΔL = deflection

XLP = cross center loops

MLP = machine loops

UTS = Ultimate Tensile Strength

Calculations

$$D = OD - d$$

$$R = \frac{Gd^4}{8d^3N_A} \quad \text{and} \quad P = IT + (R * \Delta L)$$

$$S_t = \left(\frac{8 * D * P}{\pi * d^3} \right) * \left(\frac{4 * c - 1}{4 * c - 4} \right) + \frac{4 * P}{\pi * d^2}$$

$$S_b = \left(\frac{16 * D * P}{\pi * d^3} \right) * \left(\frac{4 * c^2 - c - 1}{4 * c * (c - 1)} \right)$$

$$\% \text{ tensile} = 100 \times \frac{S}{UTS} \quad \text{*See tables for MTS}$$

Common Spring Materials	Max Recommended % Tensile	
	S _t	S _b
Music Wire	45	75
Chrome Silicon	45	75
Chrome Vanadium	45	75
302 Stainless Steel	35	55
316 Stainless Steel	35	55
17-7 Stainless Steel	45	75

*See our material data sheet for a more complete list

Types of Ends

The two most common types of loops are cross center and machine. However, loops can be made to virtually any configuration required.



Cross Center Loop

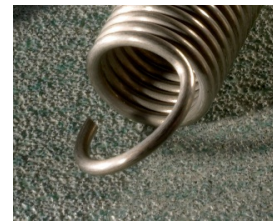

Machine Loop

Design tips

- The highest stressed point in an extension spring is where it bends to form the loop. These stresses can be difficult to calculate and you should contact M&R for critical applications
- Don't forget initial tension when calculating spring force
- The initial tension should be held between 40% and 80% of UTS for best control
- Free length is measured inside hook to inside hook



Extension Spring Reference Guide

Tolerances

The following tables give tolerances that can be used as a reference. Actual manufacturing tolerances will depend on the spring specifics. Usually Murphy and Read can manufacture to tolerances 25% smaller than the Spring Manufacturers Institute(SMI) Guidelines.

Outside Diameter Tolerances

Wire Diameter (in)	Spring Index, D/d						
	4	6	8	10	12	14	16
0.015	0.002	0.002	0.003	0.004	0.005	0.006	0.007
0.023	0.002	0.003	0.004	0.006	0.007	0.008	0.01
0.035	0.002	0.004	0.006	0.007	0.009	0.011	0.013
0.051	0.003	0.005	0.007	0.01	0.012	0.015	0.017
0.076	0.004	0.007	0.01	0.013	0.016	0.019	0.022
0.114	0.006	0.009	0.013	0.018	0.021	0.025	0.029
0.171	0.008	0.012	0.017	0.023	0.028	0.033	0.038
0.25	0.011	0.015	0.021	0.028	0.035	0.042	0.049
0.375	0.016	0.02	0.026	0.037	0.046	0.054	0.064
0.5	0.021	0.03	0.04	0.062	0.08	0.1	0.125

Spring Free Length Tolerances	
.5 in or less	0.02
0.5" to 1.0"	0.03
1" to 2.0"	0.04
2" to 4"	0.06
4" to 8"	0.093
8" to 16"	0.156
16" to 24"	0.218

- Spring rate Tolerance $\pm 10\%$
- Load at length tolerance $\pm 10\%$



Extension Spring Reference Guide

Standard Extension Springs

Selection

Extension Springs are organized in order of increasing diameter and wire size. Note that in each category the spring rate decreases as the length increases.

After identifying the proper outside diameter of the spring needed, select a range for wire diameter and free length. The broader the range of values selected the more options will be offered.

Maximum Load & Extension

The maximum loads and extended lengths are provided as a precautionary guide. They are based on a stress of 35% of tensile which is good for most applications. Even though most of these springs could be used beyond the listed lengths in light applications, there is a higher probability that the spring will deform or the loop will fail.

Determining Loads at any Length

To determine loads at lengths other than the maximum extended length multiply the amount of extension beyond the free length by the spring rate and add the initial tension.

If a spring is 1" long, has a rate of 2 lbs per inch and the initial tension is .6 lbs, what is the load at 1 3/4 inches?

$$\text{Load} = (1 \frac{3}{4} - 1) \times 2 + .6 = 2.10 \text{ lbs}$$

Ends

Machine or X-Center Loops - Random Position.

Special loops, gaps and position can be furnished upon request. The cost for special ends is based on difficulty and quantity required.

Material

Music Wire: ASTM-A228

250 degree maximum operating temperature.

Stainless Steel Type 302: ASTM-A313

500 degree maximum operating temperature.

Finish

Plain finish. Special finishes including Plating, Shot Peening and Passivation can be supplied on request. Please allow additional time.

Certification

Certificate of conformance to our specification, copies of dimensional and load testing and material certification are available at additional cost.

Tolerances

Spring Rate $\pm 10\%$
Load at Max. Length $\pm 10\%$

Outside Diameter
0.063 to 0.119 ± 0.003
0.120 to 0.240 ± 0.005
0.241 to 0.500 ± 0.008
0.501 to 1.000 ± 0.015
1.001 to 1.225 ± 0.020
1.226 to 1.460 ± 0.030
1.461 to 2.000 ± 0.040

Custom Extension Springs

If you are unable to find a suitable spring in our stock selection, please contact our engineering department for assistance.